

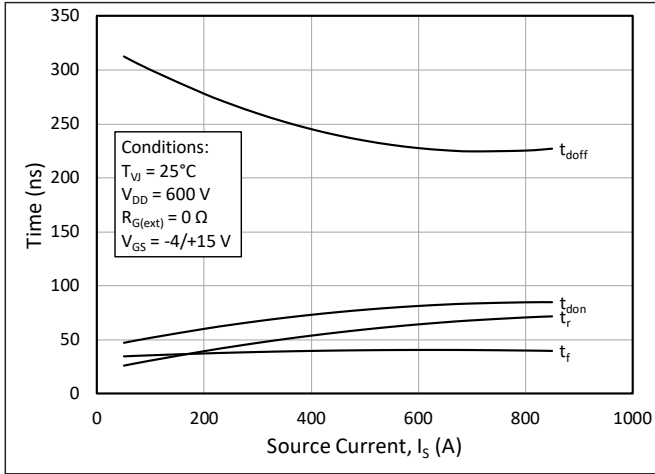

### Timing Characteristics

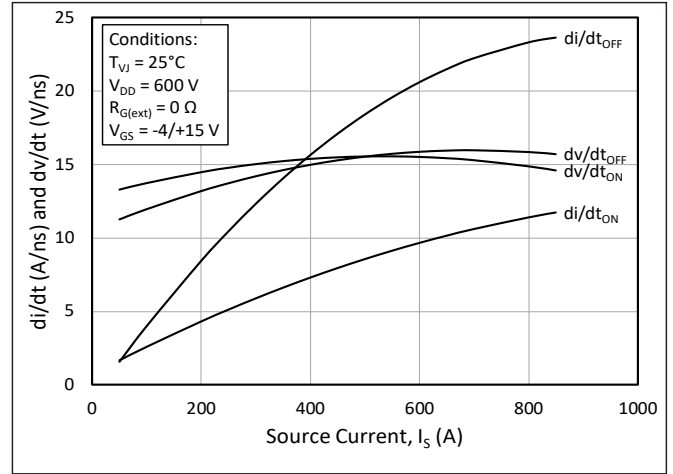

**Figure 25.** Timing vs. Source Current



**Figure 26.** dv/dt and di/dt vs. Source Current

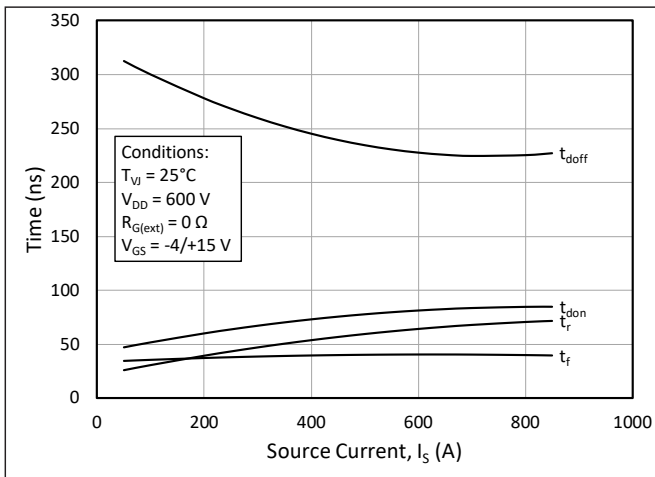

**Figure 27.** Timing vs. Junction Temperature

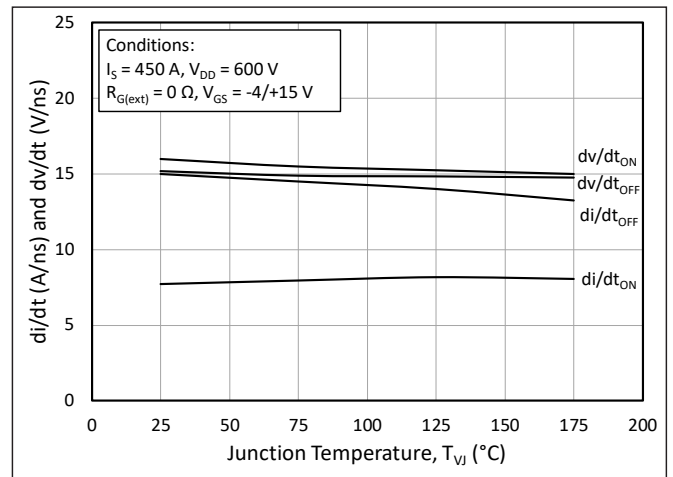

**Figure 28.** dv/dt and di/dt vs. Junction Temperature

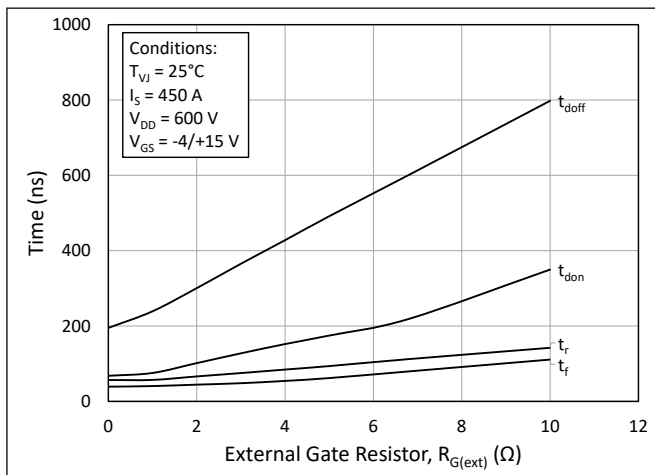

**Figure 29.** Timing vs. External Gate Resistance

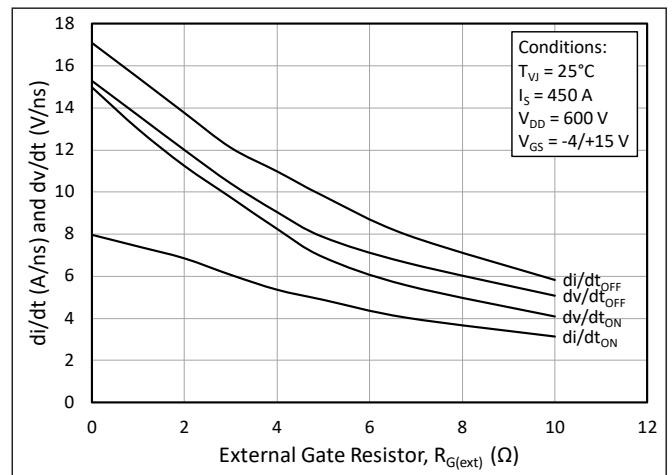

**Figure 30.** dv/dt and di/dt vs. External Gate Resistance



**Definitions**

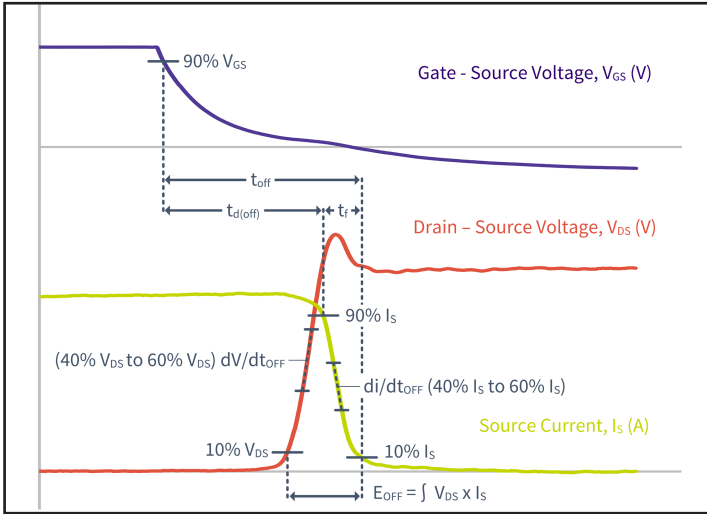

**Figure 29. Turn-off Transient Definitions**

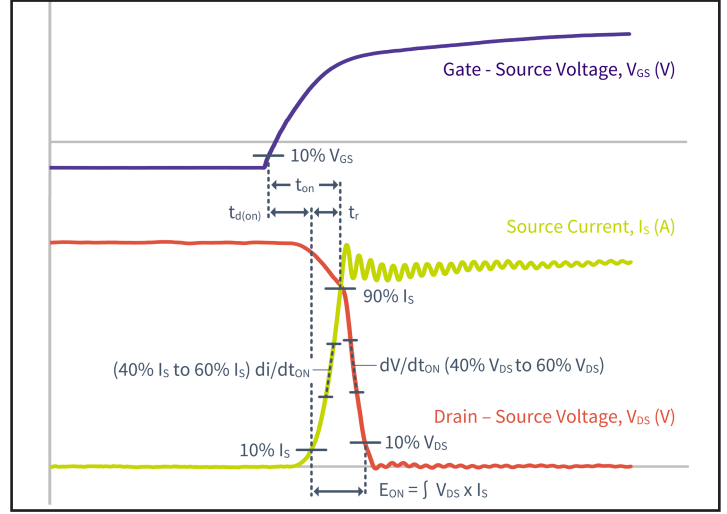

**Figure 30. Turn-on Transient Definitions**

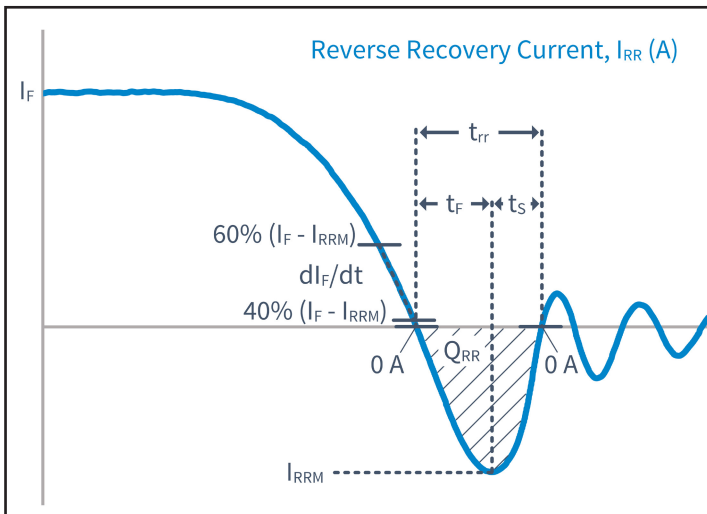

**Figure 31. Reverse Recovery Definitions**

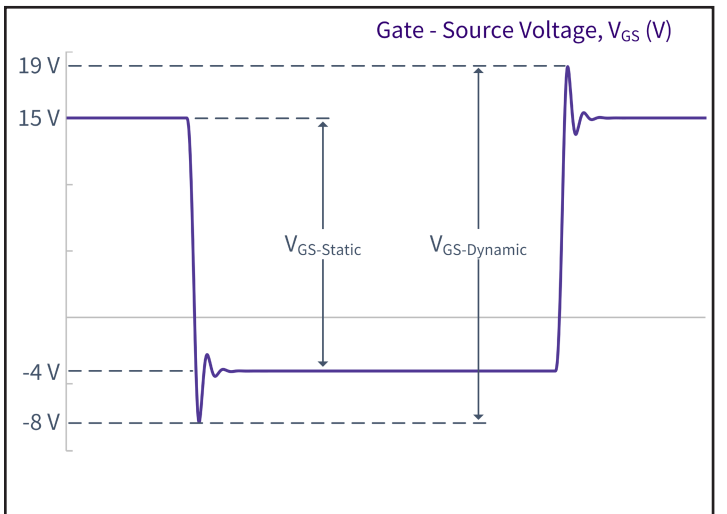

**Figure 32.  $V_{GS}$  Transient Definitions**